

Convertible Top Tension Cable

Removal

NOTE: LH shown, RH similar.

1. Remove the upper quarter trim panel cap and upper quarter trim panel. For additional information, refer to [Section 501-05](#).
2. Open the convertible top approximately half-way.
3. Remove pushpins and the front weatherstrip.

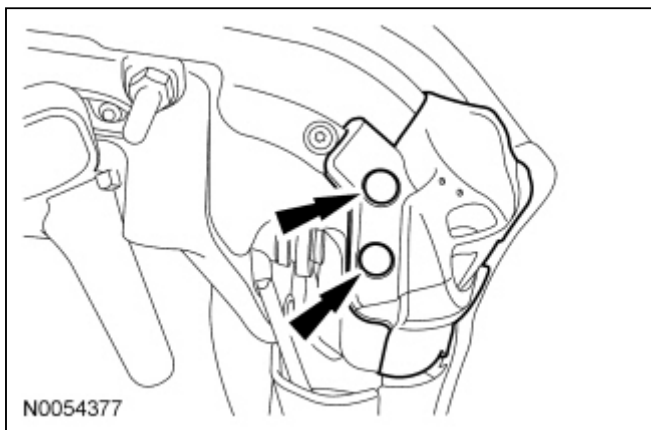

4. Remove the 2 Torx screws and the front weatherstrip retainer channel.

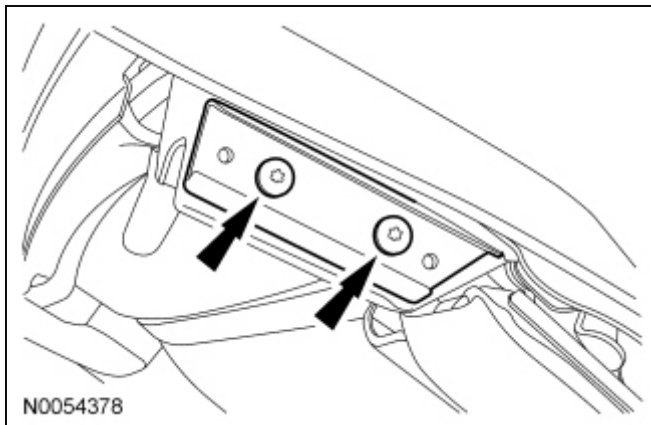

5. Drill out the rivet attaching the cable flag to the convertible top frame No. 1 bow. Once the cable flag is loose, use a small punch to knock out the rivet slug and clear the hole.

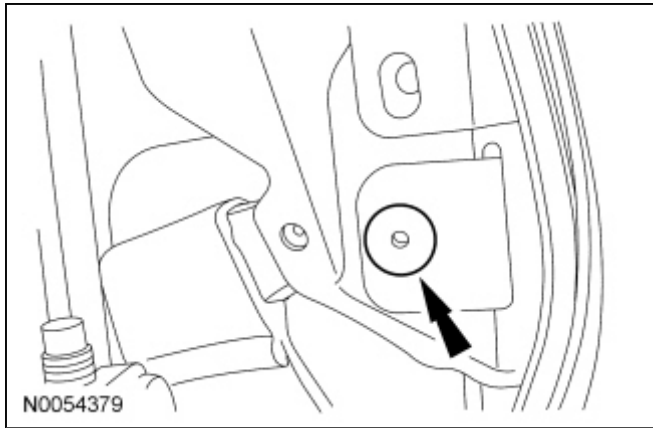

- Using side cutters, cut the cable from the cable flag (cut as close to the flag as possible).

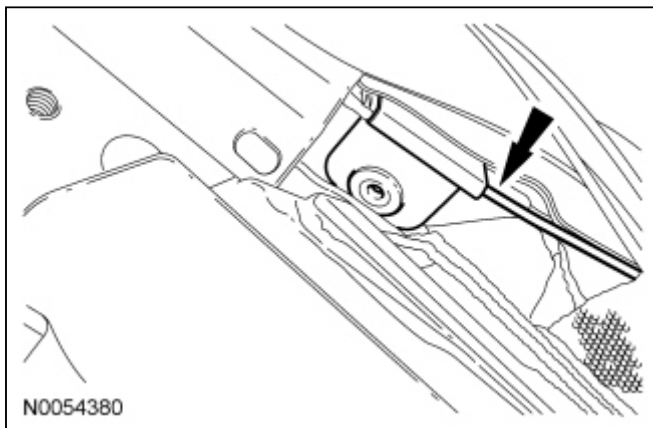

- NOTE:** Use the old cable to pull the new cable through the top.
Temporarily tie the old cable to the spring end of the new tension cable (make sure it is secure).
- Close the convertible top until it is approximately 15.25 cm (6 in) from the top of the windshield frame.
- From inside vehicle, carefully pull the old tension cable out to feed the new tension cable through the convertible top. It may be necessary to open the convertible top to get the spring of the new cable passed through the body.
- With the convertible top 15.25 cm (6 in) from the top of the window, drill out the rivet attaching the old cable to the convertible top frame No. 5 bow. Use a small punch to knock out the rivet slug and clear the hole.

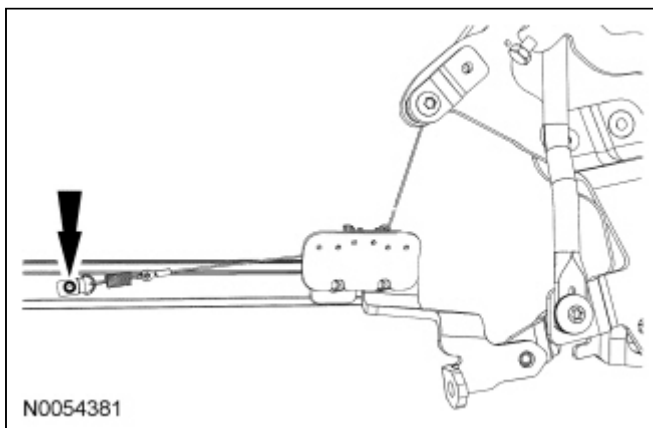

Installation

- Open the convertible top as necessary to rivet new cable flag to convertible top frame No. 1 bow.

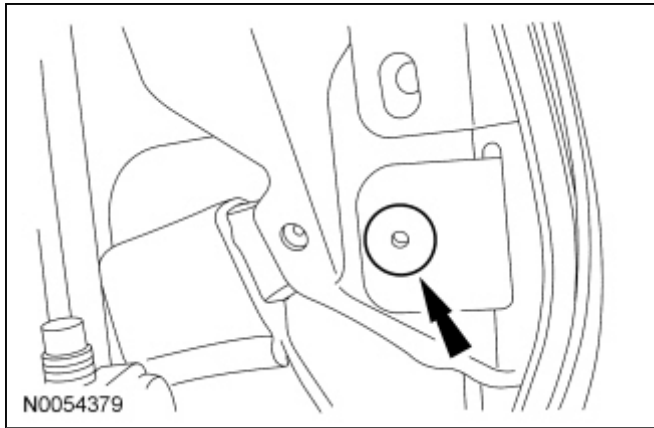

2. Pull the cable sheathing upward, approximately 15.25 cm (6 in) from the cable eyelet and position the cable into the cable guide.

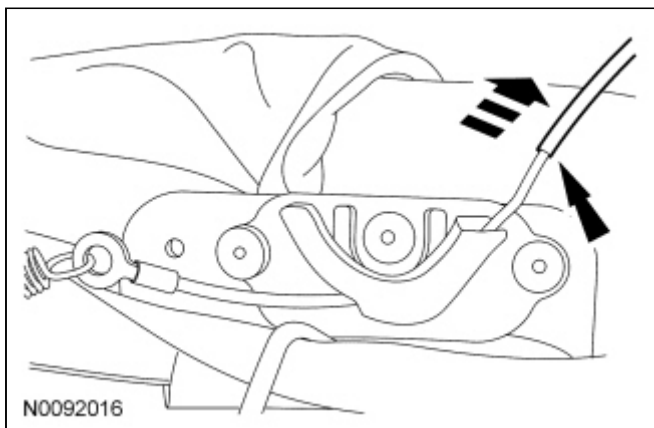

3. **NOTE:** Save the sound isolation webbing from the old cable spring so it can be transferred to the new cable spring.

Pull the old cable through the cable guide and route the new cable through the cable guide.

4. Put the sound isolation material on the new cable spring and rivet new cable to convertible top frame No. 5 bow.

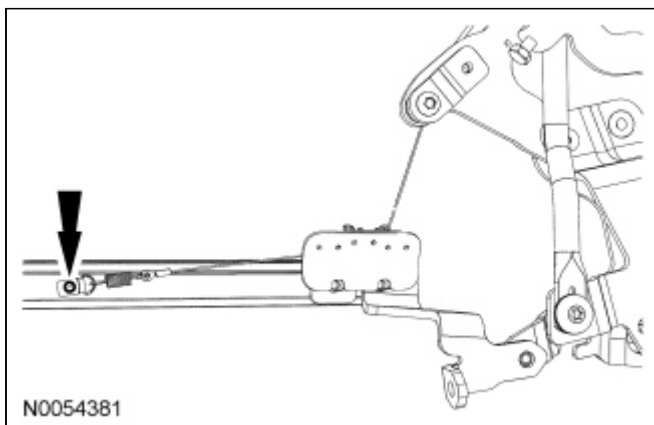

5. Install the 2 Torx screws and the front weatherstrip retainer channel.

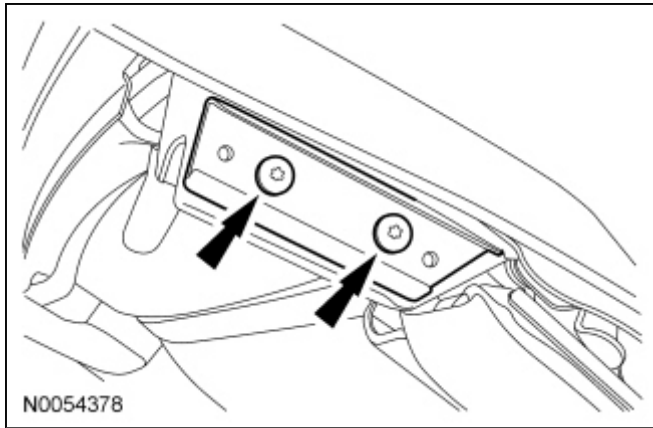

6. Install the front weatherstrip.
 - Install the 2 pushpins.

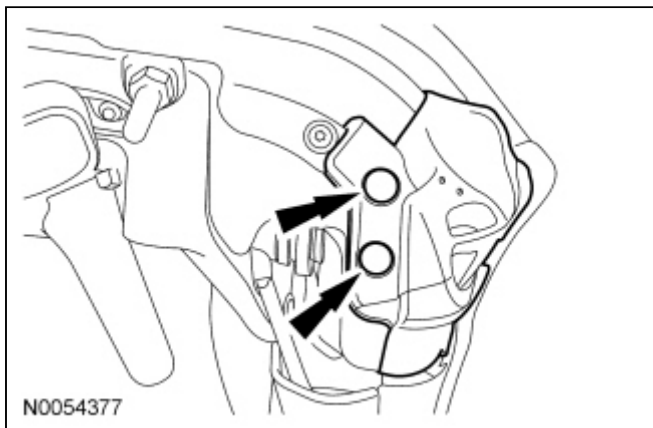

7. Close the convertible top completely.
 - Check the outside appearance of the convertible top.
 - From inside the vehicle, make sure the cable is routed through guide and cable is under tension. Repair as necessary.
 8. Install the upper quarter trim panel cap and upper quarter trim panel. For additional information, refer to [Section 501-05](#).
-

